

# TECHNICAL DATA SHEET

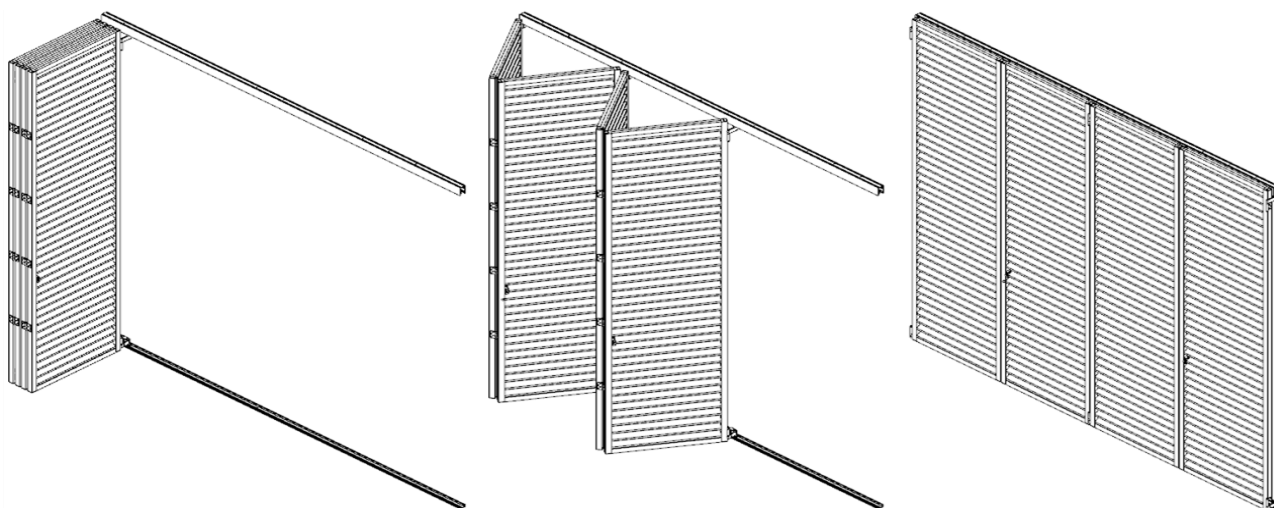

<b>SYSTEM</b>	<b>DucoSlide QuadraFold</b>
<b>DESCRIPTION</b>	Solar shading to join 4 panels on to each other, these can be opened and closed (manual control) (accordion principle).
<b>HARDWARE</b>	High quality maintenance free folding hardware
<b>PARTS</b>	Top track and bottom track with wheels / 4 slides / hinges / locks
<b>TOP TRACK</b>	48 x 75
<b>BOTTOM TRACK</b>	48 x 20
<b>PANEL DIMENSIONS</b>	Depends on windload and type of the panel. Width: min. 300 mm, max. 800 mm Height: max. 3000 mm (if windload is 50 %) Max. 800 Pa
<b>MAX. WEIGHT</b>	40 kg per panel
<b>MATERIAL</b>	Aluminium : EN AW-6063 T66 (EN 573-3)
<b>SURFACE TREATMENT</b>	- standard aluminium anodised (15-20µm) according Qualanod - polyester powder coated (60-80µm) according Qualicoat Seaside type A - specific RAL codes and/or textured paint on request
<b>COLOURS</b>	All RAL-colours or anodized (tracks included)
<b>OUTSIDE VIEW</b>	Panels hang in front of the track, hardware and track are not visible when the panels are in closed position. Hardware and track are visible when the panel is in open position.
<b>BUILT IN SIZES</b>	Width: min. 1251 mm, max. 3251 mm Height: panel height + 20 mm (10 mm top and bottom) Depth: 89 mm in closed position
<b>TYPE OF PANELS</b>	DucoSlide LuxFrame 40/40 (with the exception of Solid 30Z and 40Z)

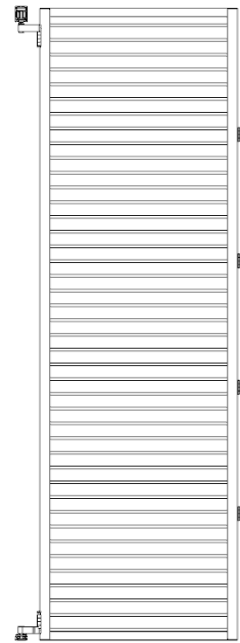

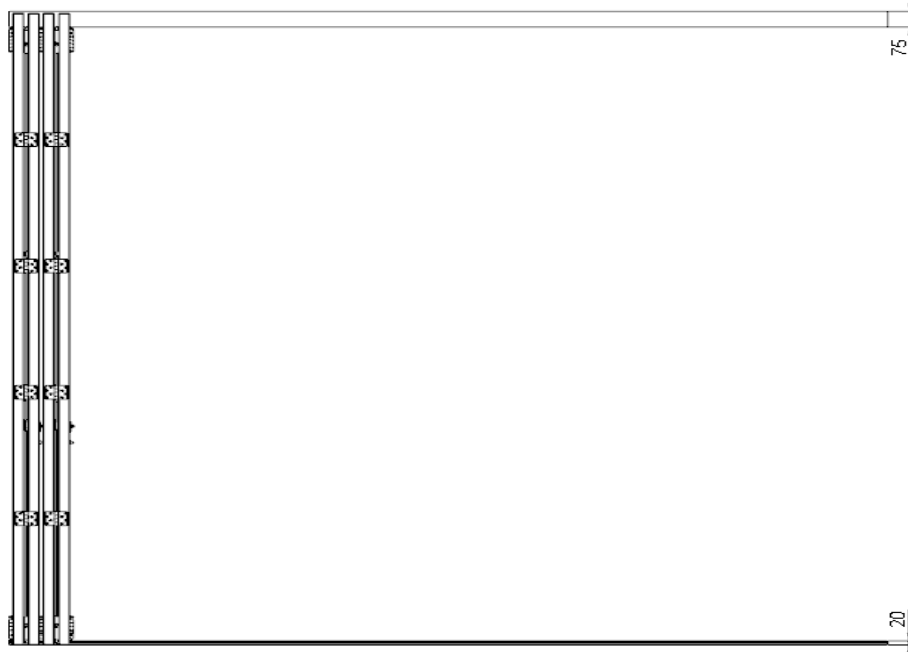
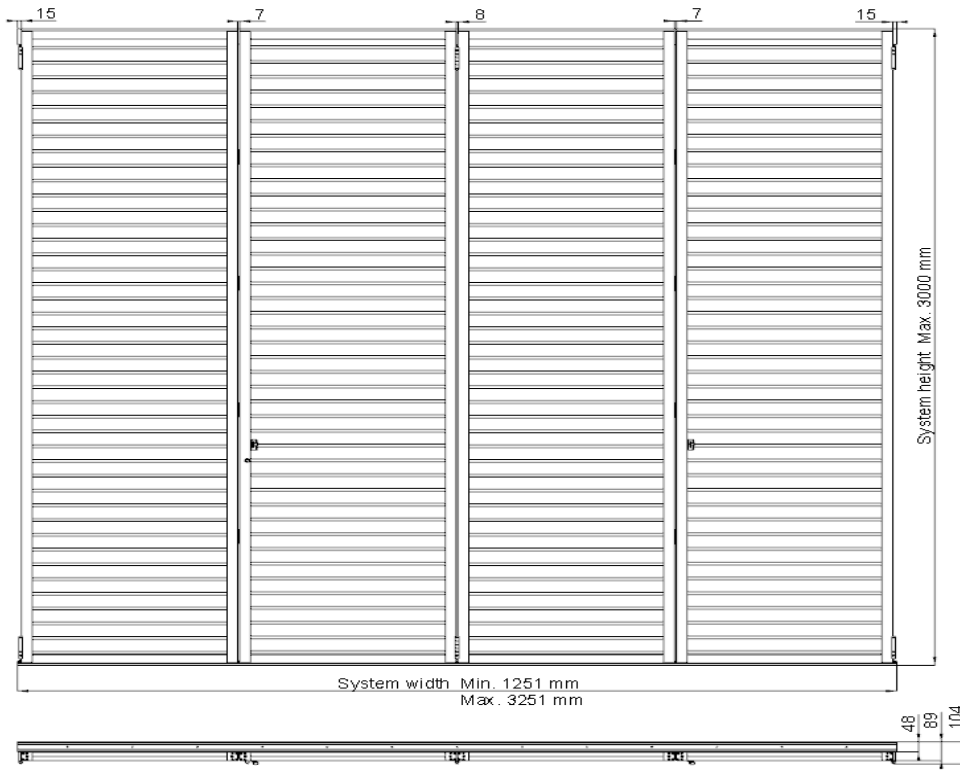

\* All images are left QuadraFold.