

Plaatsingsinstructie

Duco Dakkap Solid 30Z

26/01/2022

DUCO
Ventilation & Sun Control

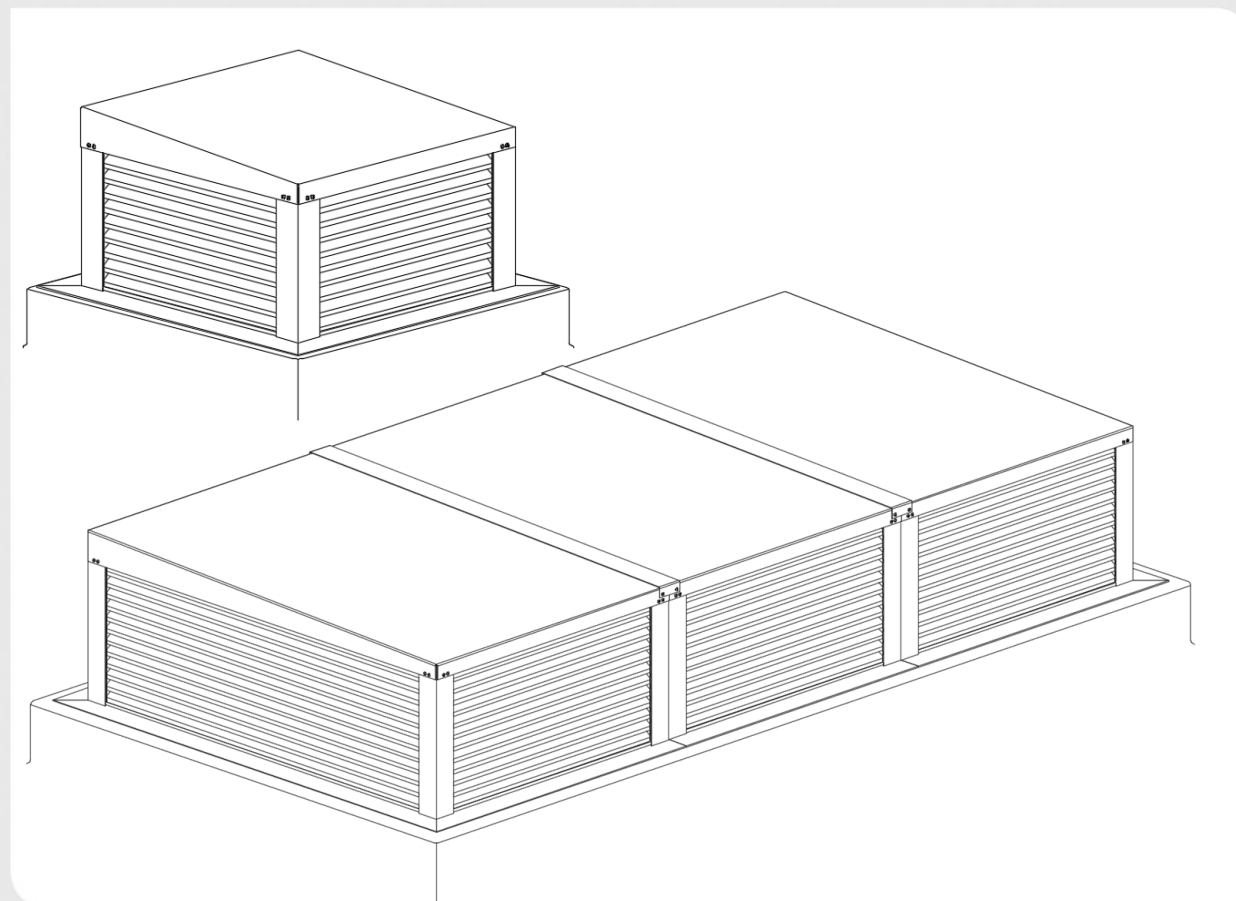

INHOUD

1. Afmeting
2. Voorbereiding
3. Plaatsing enkele module
4. Plaatsing meerdere modules

1

Afmeting

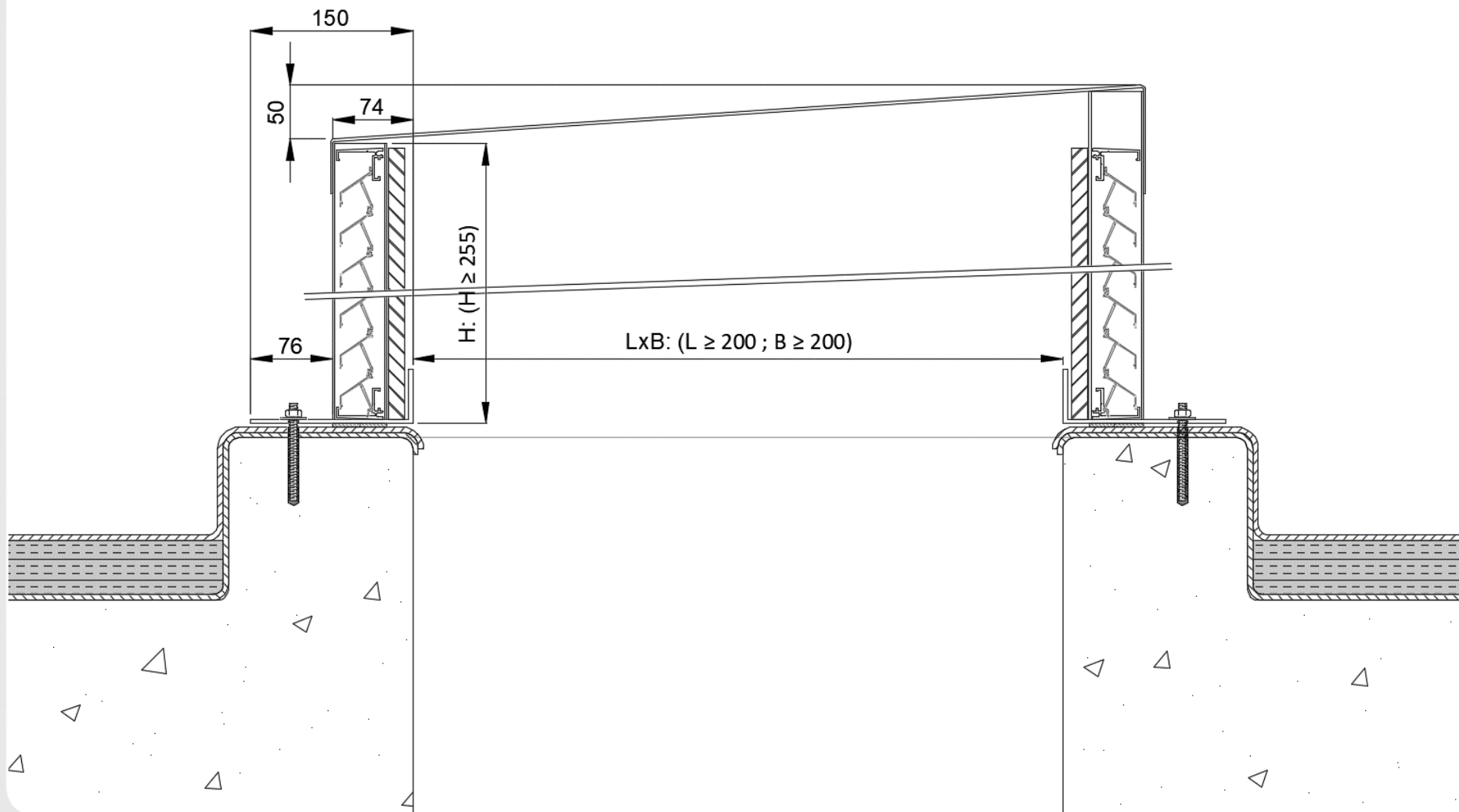

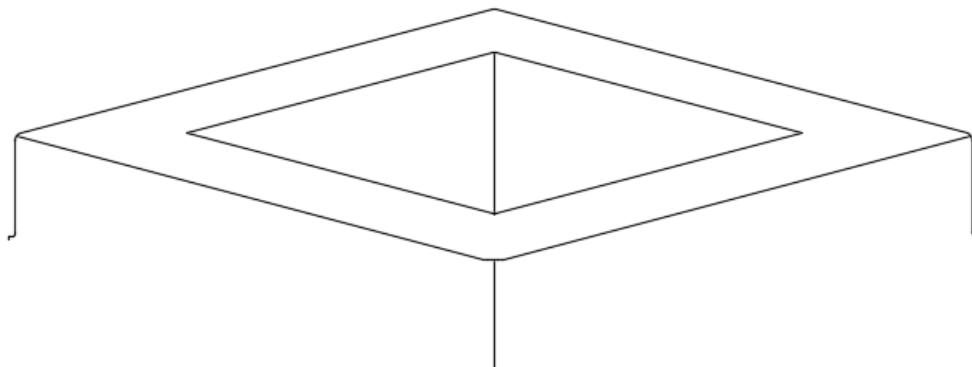

Waterkering & dampscherm komen tot over de sokkel

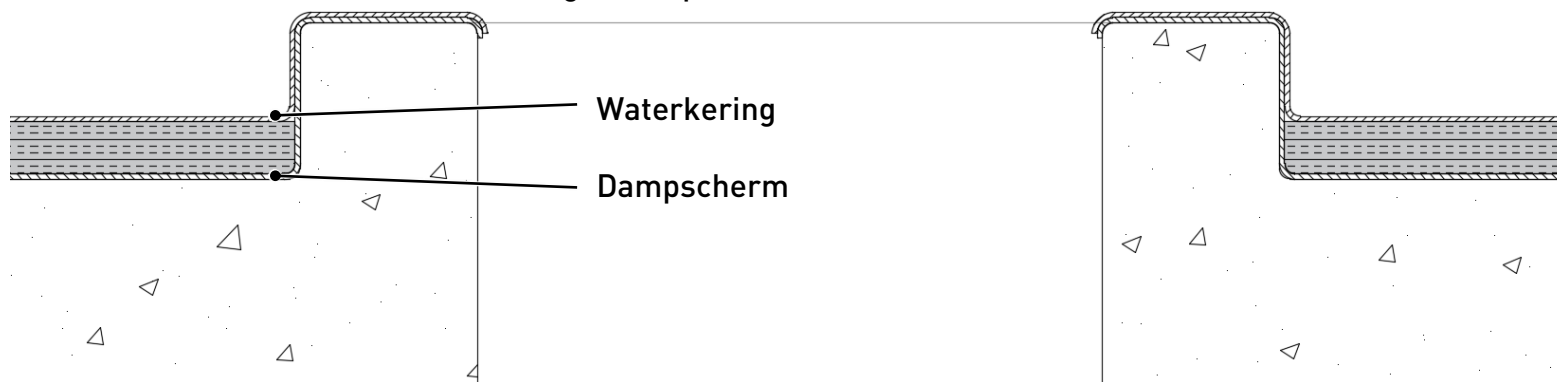

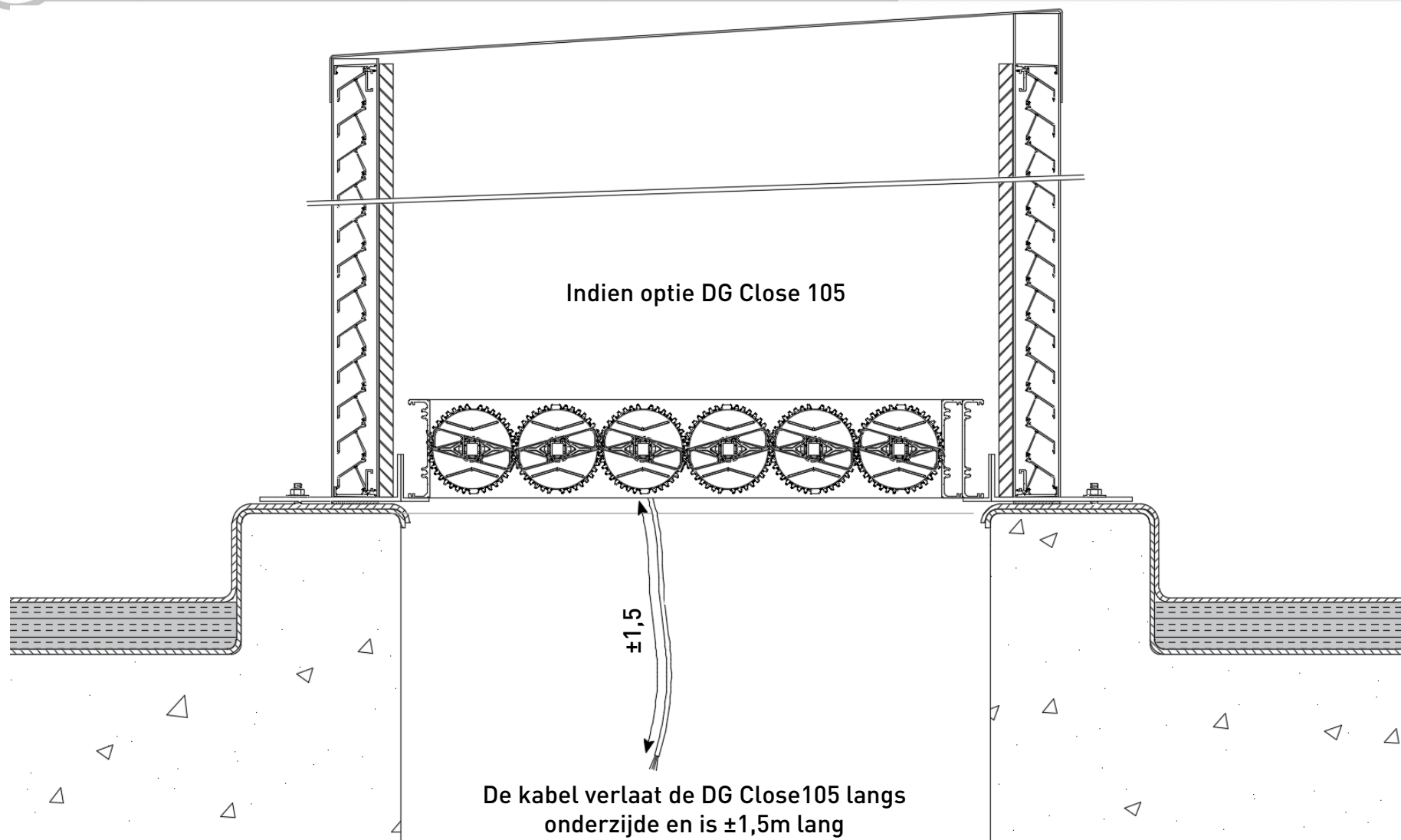

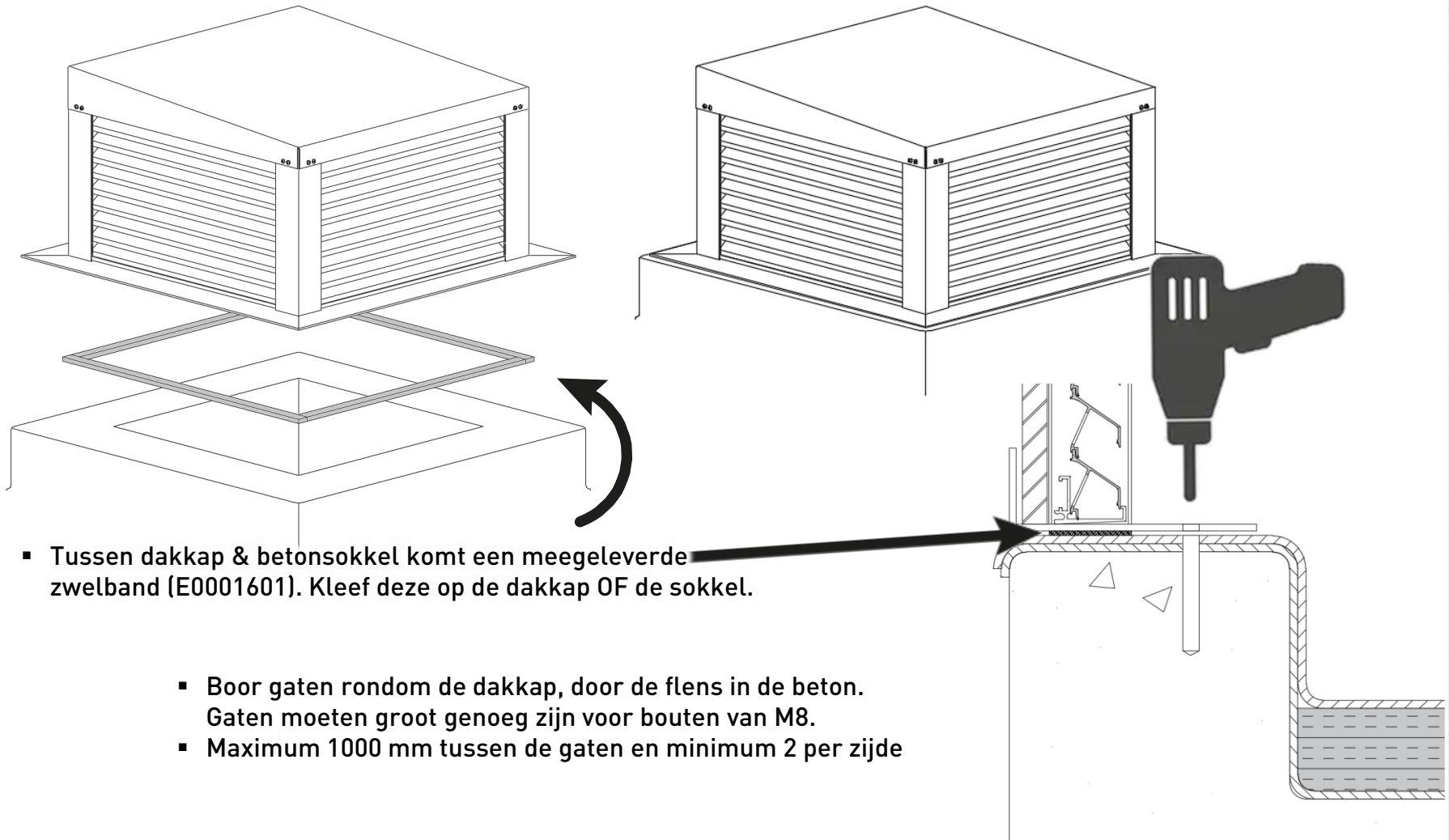

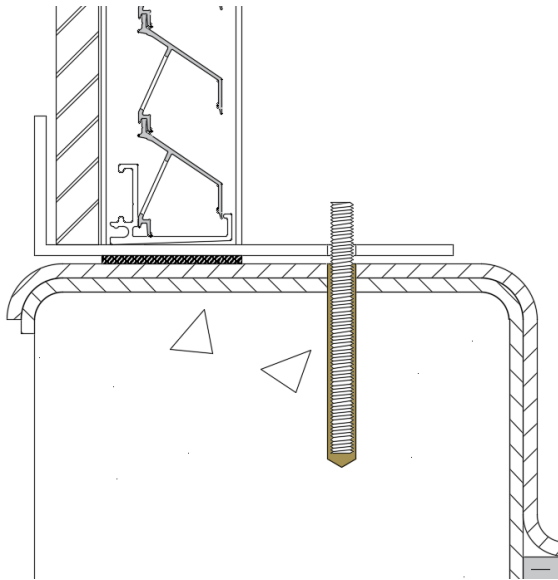

Zet draadeinde (niet meegeleverd door Duco) vast in de betonstructuur.
(vb: Chemische verankering/Injectiemortel)

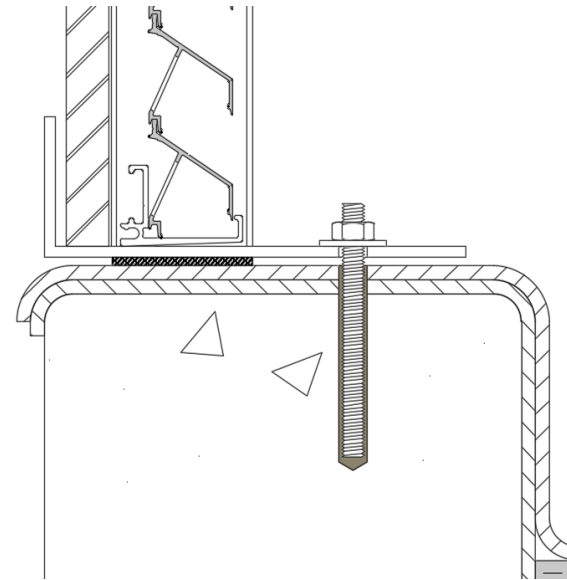

Zet de dakkap vast met moer en rondsel
(niet meegeleverd door Duco)

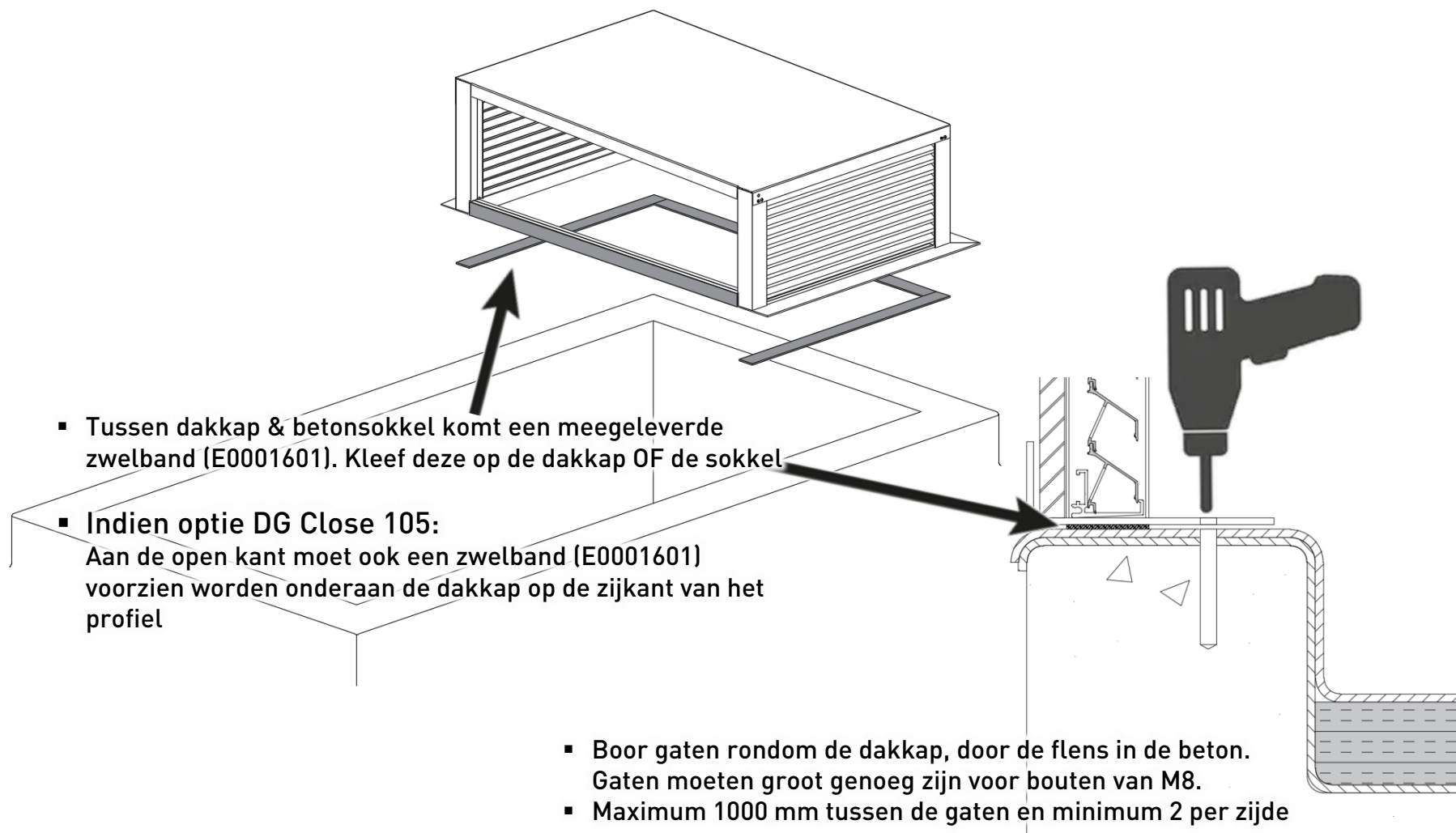

4

Plaatsing Meerdere modules

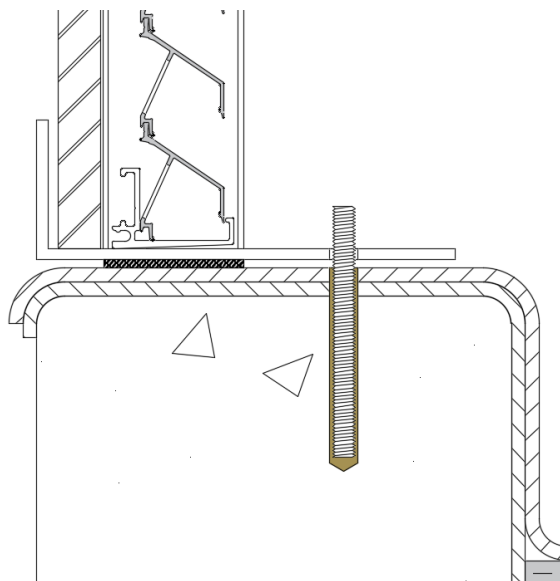

Zet draadeinde vast in de betonstructuur.
(vb: Chemische verankering/Injectiemortel)

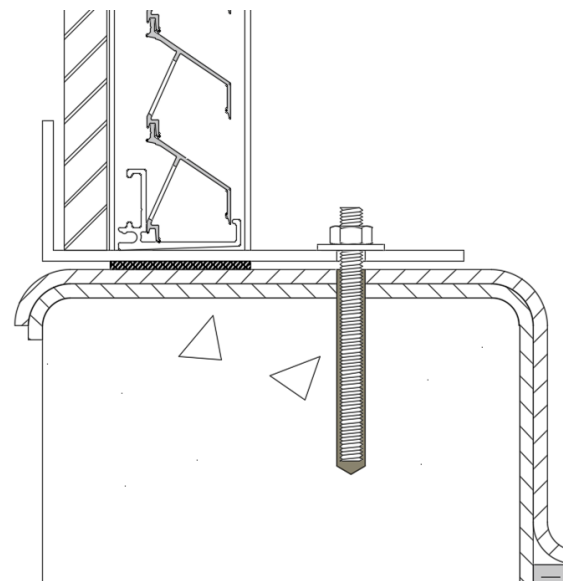

Zet de dakkap vast met moer en rondsel

Indien geen middenmodules: Deze stap over slaan

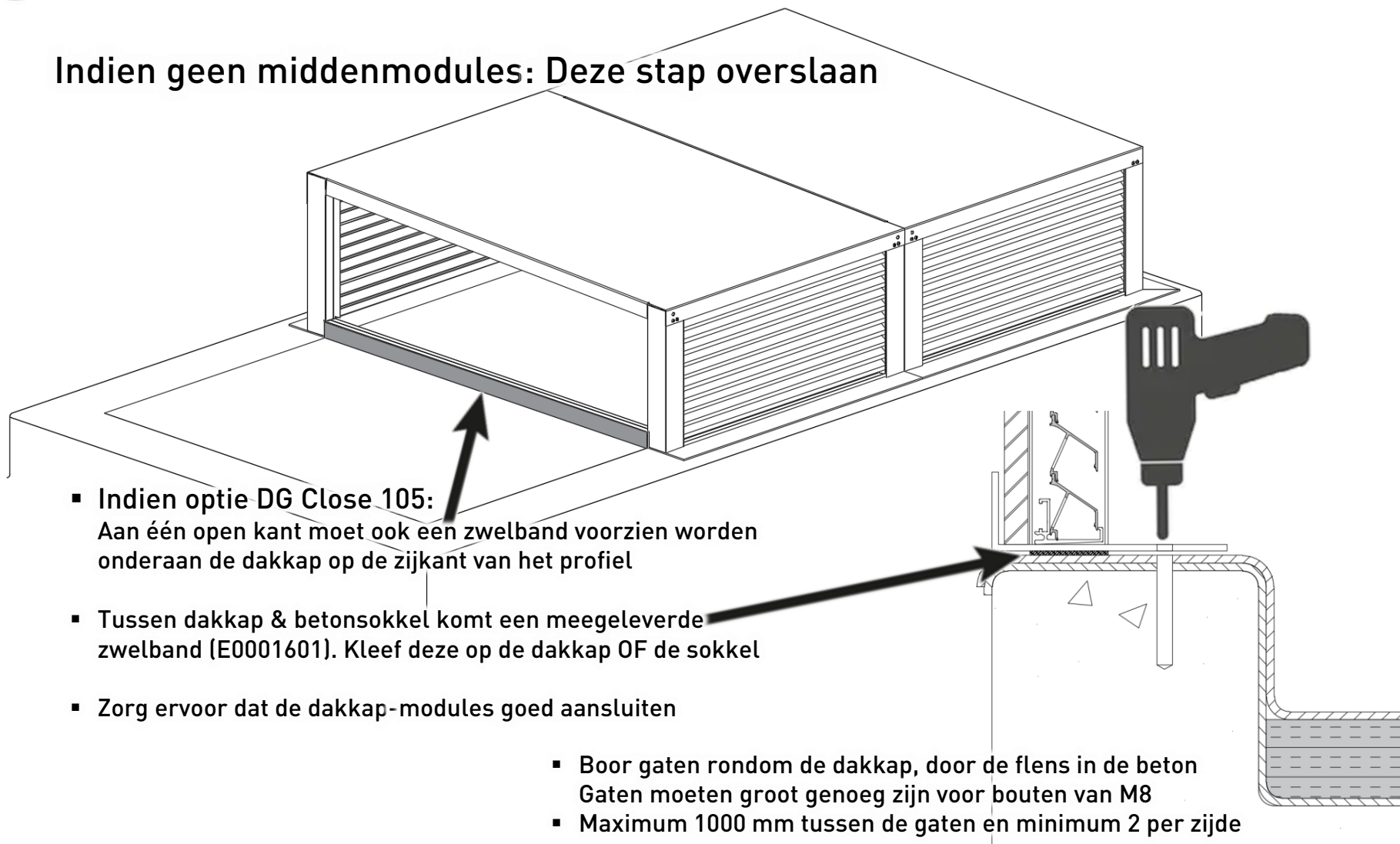

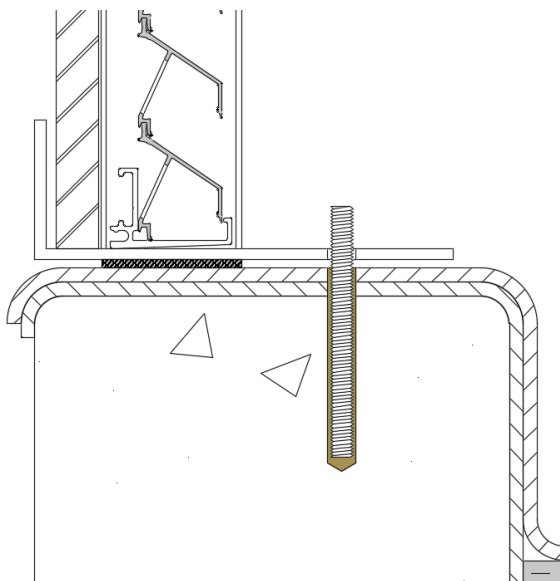

Zet draadeinde vast in de betonstructuur.
(vb: Chemische verankering/Injectiemortel)

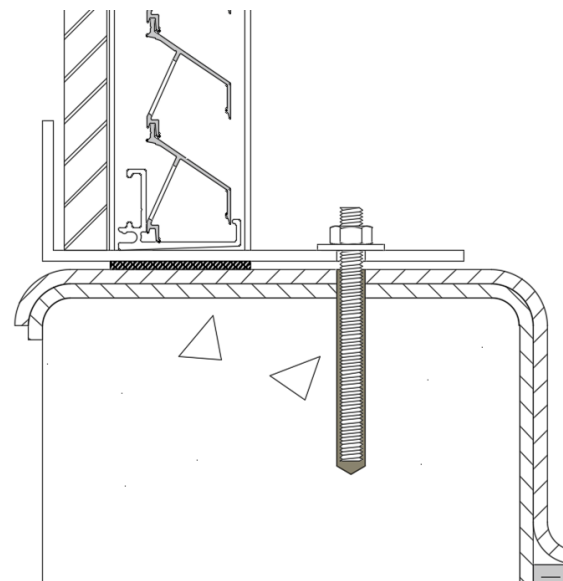

Zet de dakkap vast met moer en rondsel

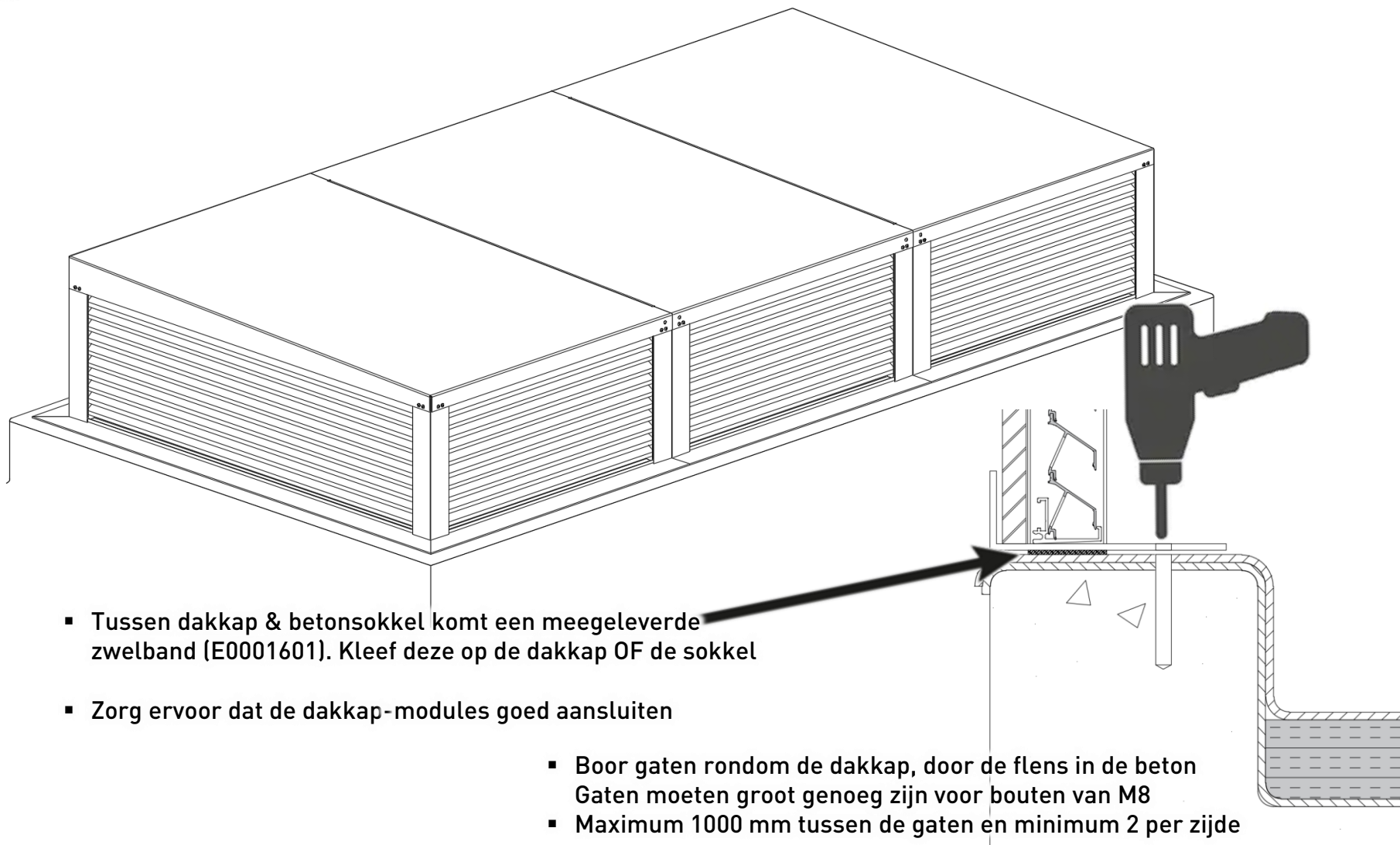

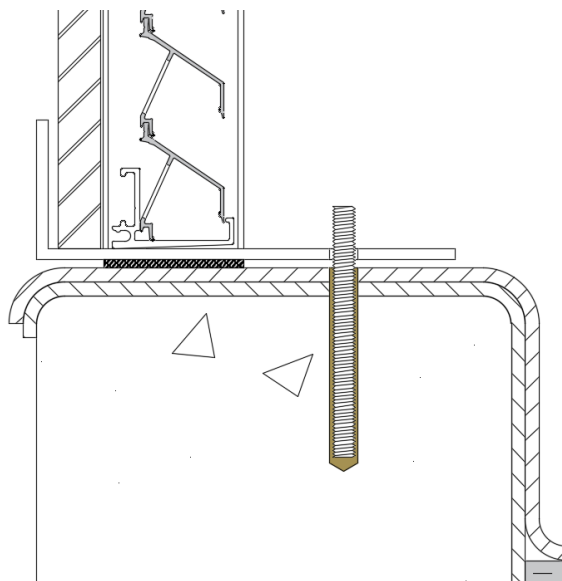

Zet draadeinde vast in de betonstructuur.
(vb: Chemische verankering/Injectiemortel)

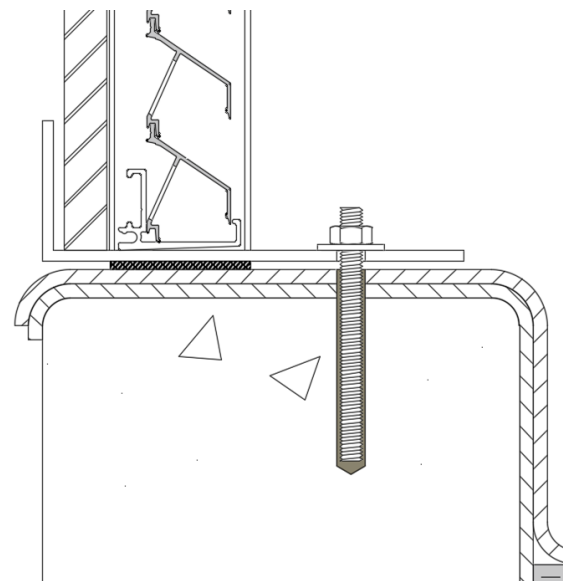

Zet de dakkap vast met moer en rondsel

Voorzie koppelplaat (G012007) van dubbelzijdige tape (E0001612)

