

TECHNICAL DATA SHEET

DucoBox Energy Comfort Plus D350

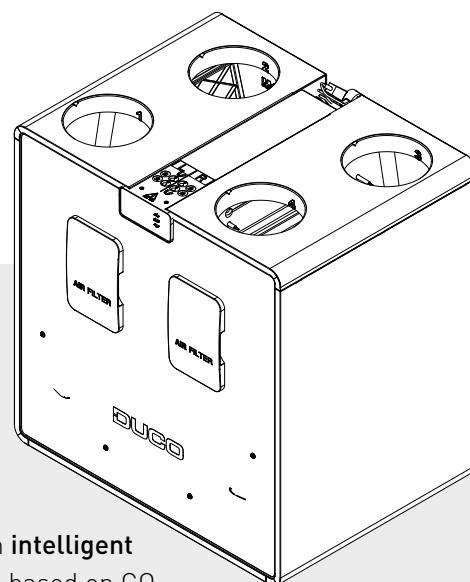

The DucoBox Energy Comfort Plus D350 is a **mechanical ventilation unit with heat recovery**. DucoBox Energy Comfort Plus was developed with the aim of guaranteeing an even quieter operation. Within the DucoBox Energy Comfort range, the left/right exchange is 100% software-driven thanks to the patented principle of the double by-pass.

The demand control of the DucoBox Energy Comfort Plus D350 results in **intelligent and energy-efficient operation**. Together with the smart demand control based on CO₂ and humidity, the dynamic air distribution filters ensure exceptional efficiency within this compact unit.

The compact and quick-to-install 2-zone valves provide the most energy-efficient result that can be achieved with an MVHR system. Please note that the zone control reduces the noise by **at least 30%**! Comfort rules!

Versions

Type	Certified by Passive House Institute	Supply and extraction capacity at 150 Pa	Supply and extraction capacity at 200 Pa	2-zone system	Frost protection	Article number
DucoBox Energy Comfort Plus D350		350 m ³ /h	350 m ³ /h	yes (external - optional)	imbalance or external heater (optional)	0000-4707

Physical characteristics

Width x Height x Depth (mm)	760 x 803 x 584
Casing	Coated sheet steel
Colours	White + green
Connections	Inner diameter: Ø 180 mm
Condensate drain	Ø 32 mm (1 ¼") (2x)
Heat exchanger	v1: PP - v2: PET/Alu
Material of inside section	EPP / PP / ABS
Weight	47 kg
Power cable length	2 m (from top of unit)
Mounting	Wall mounting (standard) Floor mounting as an option using a support frame

Electrical characteristics

Maximum power at 50 Pa	92,7 W
Power supply	230 V, 50 Hz via 3-core power cable with earthed plug
Contacts	0-10 V in/output
Type of motor	DC
IP class	IP40
Energy conversion efficiency	88.9% (EN 13141-7) 83% (Passive House Institute)

Miscellaneous characteristics

Energy class	With 2 sensors (control factor 0.65): A+ Other: A
Filters	Dynamic airflow filter supply air (520 x 190 x 15 mm) Standard: ISO 16890 Coarse 65 % (= G4) Optional: ISO 16890 ePM1 55% (=F7) Dynamic airflow filter exhaust air (520 x 190 x 15 mm) Standard: ISO 16890 Coarse 65 % (= G4)
Fans	EC fan with backward curved blades
Automatic calibration	Yes (constant pressure)
Installer App	Via Duco Connectivity Board (if permanently mounted) Via Duco Installation Kit (mobile application)
Passive cooling	Automatic passive cooling control via 'NightBoost' function
Operation	Integrated display Use via remote controls and CO ₂ or Humidity Sensors Optional via smartphone/tablet (provided Duco Connectivity Board in device)
Sensors	Integrated: pressure, temperature, onboard switch sensor External: CO ₂ (via optional Room sensor), Humidity (via optional Room sensor or measurement in ETA duct), external Switch Sensor (voltage-free input) (optional)
Communication	Standard: Duco RF, Duco Wired, Switch Sensor Expandable with Duco Connectivity Board: Modbus TCP (local), REST API (local or via cloud) - both via Ethernet or Wi-Fi

Pressure/flow characteristics

Flow rate (m ³ /h)	Pressure (Pa)	Absorbed power* (W)
322	250	118
300	250	108
250	250	89
200	250	73
350	200	117
300	200	94
250	200	76
200	200	61
350	150	98
300	150	78
250	150	62
200	150	49

* The values mentioned are an estimate and cannot be used as substantiation.

DucoBox Energy Comfort Plus D350

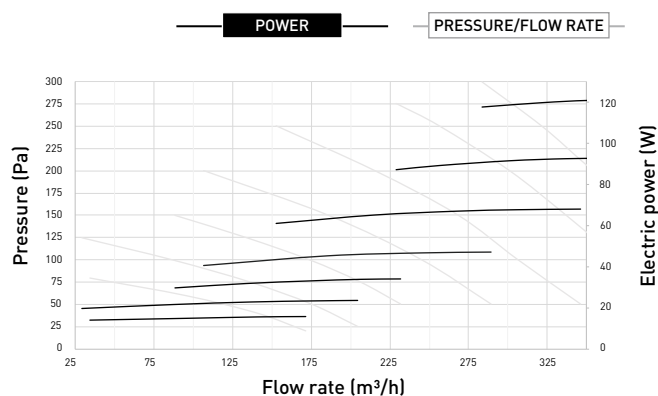

Optional accessories

Product	Article number
Siphon flat (Energy)	0000-4376
Duco Connectivity Board	0000-4810
Humidity Sensor (DucoBox Energy Comfort (Plus))	0000-4723
Mounting chair standing (Energy Comfort D400 / Plus)	0000-4740
Filter set 2 x Coarse 65% (Energy Comfort D400 / Plus)	0000-4741
Filter set Coarse 65% / ePM1 55% (Energy Comfort D400 / Plus)	0000-4742
Set Coaxial cable 8m	0000-4418
Pre-Heater DucoBox Energy Comfort (Plus) 1425W	0000-4807
External Multizone Valves	Miscellaneous

Acoustic properties

Emission from casing measured in accordance with ISO 3741:2010
 Supply and extraction noise level according to ISO 5135:1997 (with duct correction)

1. Emission from casing

Measurement #	Flow rate m³/h	Pressure Pa	LwA emission from casing dB(A)	Octave band frequencies Hz							
				63	125	250	500	1000	2000	4000	8000
1	350	200	56,5	43,8	53,3	61	54,1	45,4	43,2	39,5	<28.9
2	300	200	53	39,7	51,6	57,6	48,5	43,1	41,3	36,6	<25.0
3	350	150	54,5	45,3	51,8	59,8	49,9	43,9	41,7	38,5	<28.6
4	300	150	53,5	<40.6	50,2	59,3	46,9	41,7	39,7	35,6	<24.6
5	350	100	53,5	41,6	49,3	58,9	48,1	42,4	40,1	37,3	<28.0
6	300	100	51,5	40	48,1	57,3	45,5	40,4	38,2	34,7	<24.8
7	250	100	48,5	43,5	47,3	55,2	43,3	38,4	35,9	31,4	<20.2
8	315	50	48,5	38,3	46,2	54,7	44	38,8	36,7	33,5	<24.5
9	300	50	48,5	<36.4	45,6	55	43,1	38,1	35,8	32,6	<23.6
10	250	50	48,5	<35.4	43,4	56,6	40,9	35,4	32,9	28,8	<18.7
11	245	50	48	<35.7	43,5	56,4	40,9	35,2	32,7	28,4	<18.0
12	200	50	42,5	<30.8	39,9	50,9	39,3	32,3	29	<22.5	<10.0
13	200	25	40	<33.2	40,9	47,5	37,3	30,6	27,3	<21.3	<11.0
14	150	25	34,5	<32.7	<39.7	39,3	31,3	26,6	21,9	<12.7	<7.9
15	100	25	30	<32.9	35,3	35,1	26,9	22,5	15,6	<4.9	<7.3

2. Supply noise

Measurement #	Flow rate m³/h	Pressure Pa	LwA supply dB(A)	Octave band frequencies Hz							
				63	125	250	500	1000	2000	4000	8000
1	350	200	74,5	71,7	70,5	78,8	72,3	64,7	60,6	56,9	52,1
2	300	200	74	70,5	70	79,1	69,6	61,9	58,2	53,4	47,4
3	350	150	72	71	69,5	75,5	70,4	63,2	59,9	56,6	52,5
4	300	150	72,5	69,1	68,4	77,4	68,3	60,5	57,2	53,3	48,2
5	350	100	73	70,1	69,1	77,7	69,7	61,9	58,9	56	52,5
6	300	100	72	68,7	67,2	78,5	67	59	55,7	52,4	47,9
7	250	100	68,5	66,8	65,4	75,7	63,4	56,5	52,1	47,4	40,8
8	315	50	68,5	67,9	66,8	74	66,5	58,8	55,4	52,4	48,7
9	300	50	69	67,8	66,4	75,8	64,9	57,9	54,5	51,5	47,7
10	250	50	65	65,3	64,4	72,4	61,6	54	50,3	46,5	40,9
11	245	50	65	65	64,3	72,3	61,5	53,6	50	45,9	40,1
12	200	50	63	63,1	61,1	72,9	58,2	49,8	45,1	38,9	<29.4
13	200	25	60	63,2	63,6	67,6	57,7	48,3	43,7	38,1	<29.0
14	150	25	54,5	61,9	65,2	56,5	50,5	42,9	36,3	27,3	<14.7
15	100	25	49	60,7	62,1	51,5	44,7	36	26,9	<13.2	<9.7

3. Extraction noise

Measurement #	Flow rate m³/h	Pressure Pa	LwA extraction dB(A)	Octave band frequencies Hz							
				63	125	250	500	1000	2000	4000	8000
1	350	200	57,5	61,4	59,5	62,8	54	48	39,4	35,4	29,7
2	300	200	56,5	59,1	58,8	62,4	51,1	45,7	37,1	32,2	<25.4
3	350	150	56,5	60,2	58,6	61,9	52	46,3	38,1	34,4	<29,1
4	300	150	57,5	58,6	57,4	63,6	49,8	44,2	35,8	31,5	<25.5
5	350	100	57	58,5	56,8	63,1	50,2	45	37	33,7	<29,1
6	300	100	59,5	57,6	55,6	67,2	47,7	42,8	34,5	30,6	<25.2
7	250	100	53	<55.5	54	60,7	45,5	40,5	31,3	26,2	<19.2
8	315	50	57,5	<55.9	54	66,4	46,8	42,3	34	30,7	<26.3
9	300	50	56,5	<55.1	53,4	64,4	45,5	41,2	32,9	29,4	<24.8
10	250	50	51	<53.8	51,1	59,3	43,9	38	29,2	25	<19.0
11	245	50	48	54,9	51,5	55,7	43,3	37,5	28,6	24,1	<17.6
12	200	50	45,5	<53.3	49,1	54,1	39,9	34,3	24,4	<18.6	<10.3
13	200	25	43	55,3	49,4	50,7	38,3	32,4	23	<16.6	<9.8
14	150	25	42	<51.5	52,8	46	33,8	27,7	16,7	<8.7	<7.5
15	100	25	36	<49.5	47,1	41,5	28,5	22,2	<9.2	<1.6	<7.4

Dimensions of DucoBox Energy Comfort Plus D350

Front view

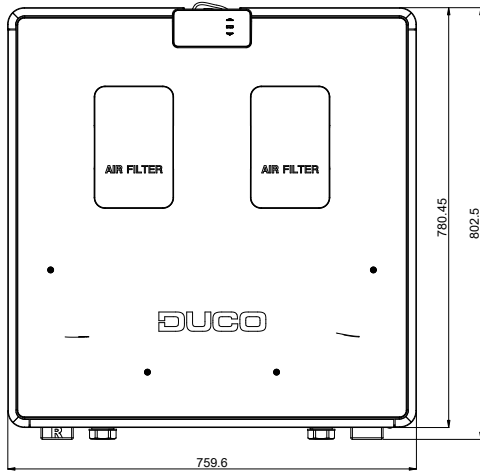

Rear view

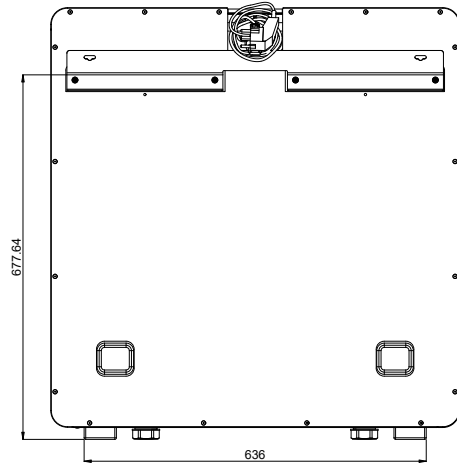

Top view

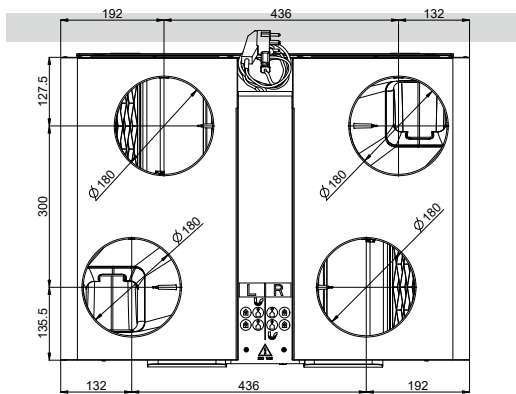

Bottom view

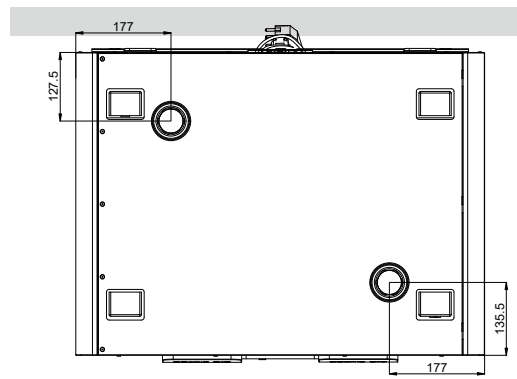

Side view

