

TECHNICAL DATA SHEET

DucoBox Energy Premium 400

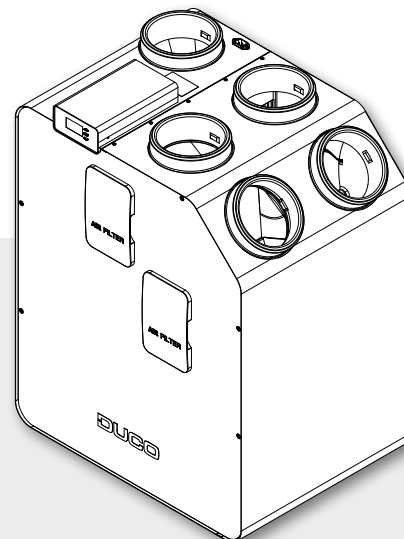

The DucoBox Energy Premium is a **mechanical ventilation unit with heat recovery**. The unit supplies fresh air mechanically to and extracts stale air mechanically from the home with the help of integrated fans. During this process, the heat is recovered from the exhaust air and transferred to the outdoor air.

The optional, integrated **2-zone system** with demand control ensures extremely **quiet, intelligent and energy-efficient operation**. Control components can be paired with the DucoBox Energy Premium (= master unit). The DucoBox Energy Premium features a frost protection system (with or without heater), a bypass function and constant flow. **Semi-automatic calibration** ensures the device can be installed quickly.

Versions

Type	Supply and extraction capacity at 150 Pa in m ³ /h	2-zone control	Frost protection	Article number	
				LEFT	RIGHT
DucoBox Energy Premium 400-1ZS	400	no	imbalance	0000-4366	0000-4367
DucoBox Energy Premium 400-1ZH			imbalance + heater	0000-4368	0000-4369
DucoBox Energy Premium 400-2ZS		Yes	imbalance	0000-4370	0000-4371
DucoBox Energy Premium 400-2ZH			imbalance + heater	0000-4372	0000-4373

Optional accessories

Product	Article number
Mounting chair standing (Energy Premium)	0000-4421
Mounting chair hanging (Energy Premium)	0000-4422
Siphon flat (Energy)	0000-4376
Duco Connectivity Board	0000-4810
Humidity Box sensor (Energy Premium)	0000-4374

Physical characteristics

Width x Height x Depth (mm)	740 x 957 x 585
Casing	Coated sheet steel
Colours	White + green
Connections	Internal diameter: Ø 160 mm External diameter: Ø 190 mm
Condensate drain	Ø 32 mm (1 ¼")
Heat exchanger	PET / Polystyrene
Material of inside section	EPP / PP / ABS
Weight	47 kg
Power cable length	2 m (to be connected to the top of the unit)
Mounting	Wall mounting (standard) Floor mounting as an option using a support frame

Electrical characteristics

Maximum power at 50 Pa	160,4 W
Maximum heater power	1000 W
Power supply	230 V, 50 Hz via 3-core power cable with earthed plug
Type of motor	DC
IP class	IP40
Energy conversion efficiency	88 % (EN 13141-7)

Miscellaneous characteristics

Energy class	Control factor 0.65: A+ Other: A
Filters	Filter supply air (175 x 500 x 25 mm) Standard: ISO 16890 Coarse 65 % (= G4) Optional: ISO 16890 ePM1 70% (= F7) Filter exhaust air (175 x 500 x 25 mm) Standard: ISO 16890 Coarse 65 % (= G4)
Summer by-pass	Fully (100% modulating)
Frost protection	Imbalance Via proportional heater as an option
Fans	EC fan with backward curved blades
Automatic calibration	Yes (constant pressure)
Constant flow regulation	Yes
Operation	Integrated display Use via remote controls and CO ₂ or Humidity Sensors
Sensors	Integrated: pressure, temperature, humidity (via optional Box sensor), onboard switch sensor External: CO ₂ Room sensor (via optional room sensor), Humidity (via optional room sensor), external switch sensor (voltage-free input) [optional]
Communication	Standard: Duco RF, Duco Wired, Switch Sensor Expandable with Duco Connectivity Board: Connection possible via REST API (locally or via the cloud) or Modbus TCP

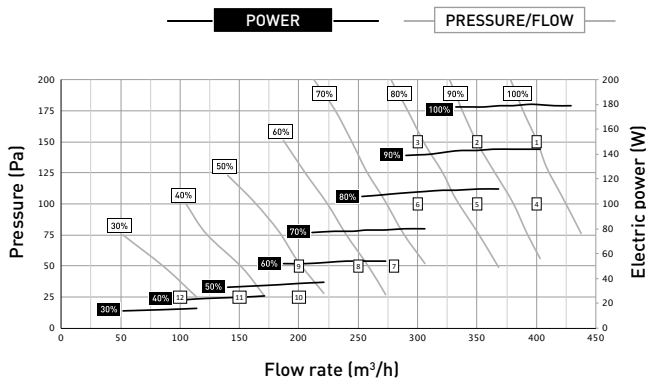

Measurement #	Flow rate Qv m³/h	Pressure Pa	Absorbed power P W	SFP Wh/m³	Sound level LwA*		
					emission from casing dB	supply dB	extraction dB
1	400	150	180	0,45	52,5	57,0	55,0
2	350	150	135	0,39	51,0	56,0	53,5
3	300	150	100	0,33	51,0	55,0	50,0
4	400	100	159	0,40	52,0	56,5	54,5
5	350	100	120	0,34	51,5	55,5	51,5
6	300	100	93	0,31	48,0	52,5	50,5
7	280	50	68	0,24	46,0	47,0	46,0
8	250	50	55	0,22	44,0	46,0	43,0
9	200	50	37	0,19	39,0	44,5	40,0
10	200	25	35	0,18	36,0	40,5	40,0
11	150	25	26	0,17	31,0	36,0	39,5
12	100	25	16	0,16	28,5	35,5	39,0

* Emission from casing measured in accordance with ISO 3741:2010
Supply and extraction noise level in accordance with ISO 5135:1997 (with duct correction)

Dimensions of DucoBox Energy Premium

LEFT model

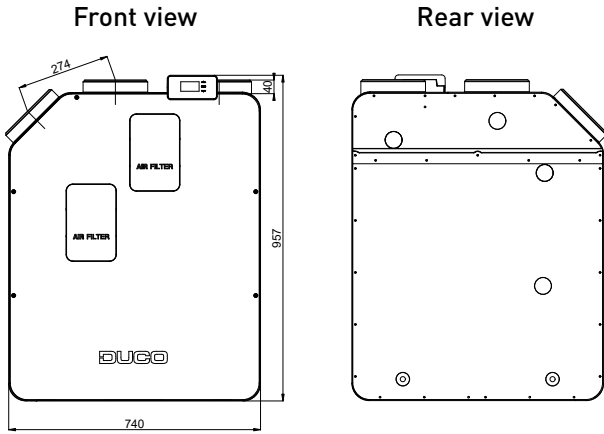

RIGHT model

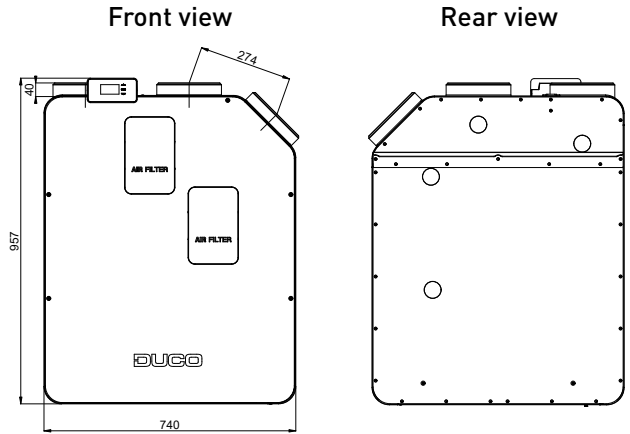

Side view

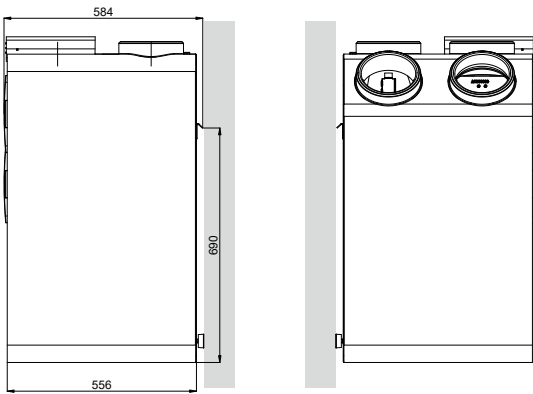

Side view

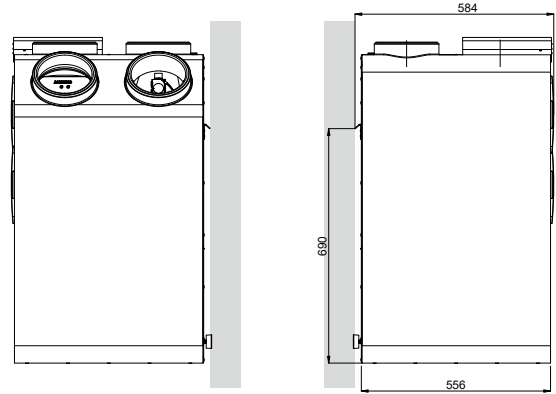

Top view

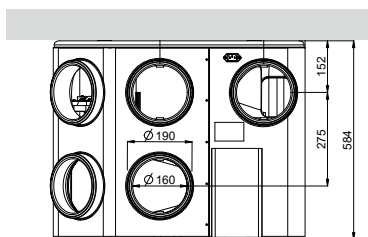

Top view

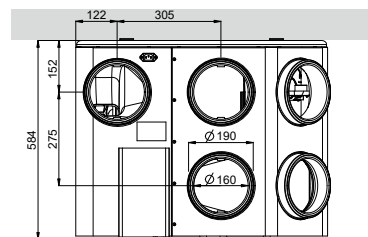

Bottom view

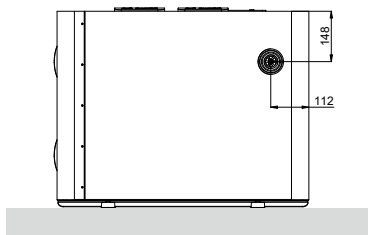

Bottom view

