

# TECHNICAL DATA SHEET

Versie : 30/09/2019

**DUCO**  
Ventilation & Sun Control

<b>TYPE</b>	<b>DUCOWALL CLASSIC W90S</b>
<b>DESCRIPTION</b>	Continuous louvre wall, extra heavy duty series
<b>SHAPE OF THE BLADE</b>	90S
<b>VISUAL FREE AREA</b>	80%
<b>PHYSICAL FREE AREA</b>	54%
<b>BLADE HEIGHT</b>	112 mm
<b>PITCH</b>	105 mm
<b>MAX. BLADE LENGTH</b>	6000 mm
<b>TYPE OF MULLION</b>	50/125, 50/50, 50/12, 21/50 MULTI or 30/12
<b>MATERIAL</b>	Aluminium : Al Mg Si 0,5 Profile thickness : min. 1,8mm Surface treatment : °standard aluminium anodised (15-20µm) °polyester powder coated (60-80µm) Thermoplastic parts : Polyamide PA 6,6 - reinforced with glass fibre
<b>COLOURS</b>	All RAL colours

K FACTOR	
Intake:	16,35
Exhaust:	17,44

WATER RESISTANCE	
BSRIA (EN13030)	
v (m/s)	Class
0	A
0,5	B
1	C
1,5	C
2	C
2,5	D

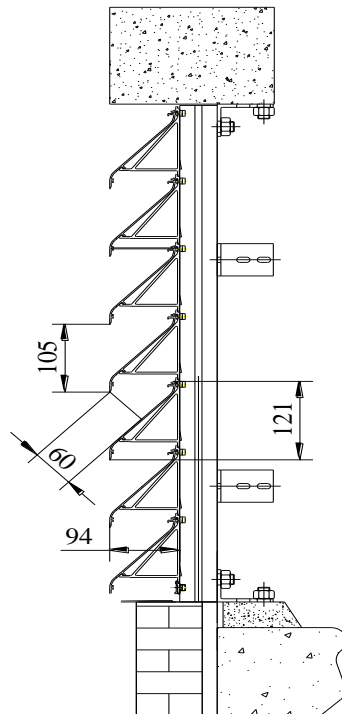

T\_N\_Ws\_W90S\_130516