

# TECHNICAL DATA SHEET

## Box sensor

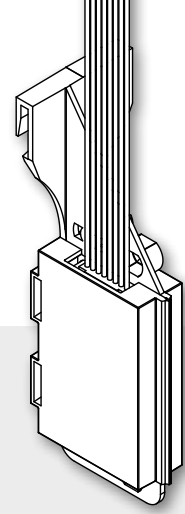

Box sensors can be integrated into the DucoBox Silent (for measuring CO<sub>2</sub> or moisture), the DucoBox Energy Premium (for measuring moisture only) and the DucoBox Reno (for measuring CO<sub>2</sub> only). A maximum of 2 box sensors can be used per DucoBox Silent: 1 CO<sub>2</sub> Box sensor and/or 1 RH Box sensor. A maximum of 1 box sensor can be used per DucoBox Energy Premium or per DucoBox Reno.

### Physical characteristics

<b>Item number</b>	4216: CO <sub>2</sub> Box sensor 4218: Humidity Box sensor 4374: Humidity Box sensor DucoBox Energy Premium 4743: DucoBox Reno CO <sub>2</sub> Box sensor
<b>Width x Height x Depth (mm)</b>	For DucoBox Silent: 113 x 43 x 36 For DucoBox Energy Premium : 56 x 42 x 16 For DucoBox Reno: 57 x 48 x 17
<b>Weight</b>	CO <sub>2</sub> Box sensor: 45 g Humidity Box sensor: 40 g DucoBox Energy Premium Humidity Box sensor: 38 g DucoBox Reno CO <sub>2</sub> Box sensor: 36 g
<b>Material</b>	PP
<b>Colour</b>	White
<b>Sensors</b>	Temperature CO <sub>2</sub> (CO <sub>2</sub> Box sensor only) Relative humidity (Humidity Box sensor only)

### Electrical characteristics

<b>Communication</b>	With DucoBox directly
<b>Power supply</b>	5 VDC (powered via the DucoBox)
<b>Peak power</b>	< 1 W
<b>Standby power</b>	< 1 W
<b>RH range</b>	0 - 100 % RH
<b>CO<sub>2</sub> range</b>	300 - 2000 ppm
<b>CO<sub>2</sub> accuracy</b>	40 ppm +/- 5%

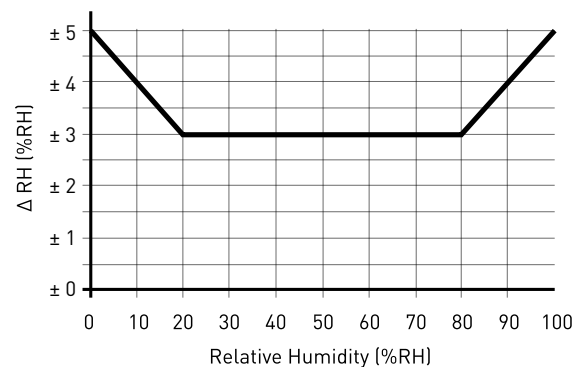

For DucoBox Silent

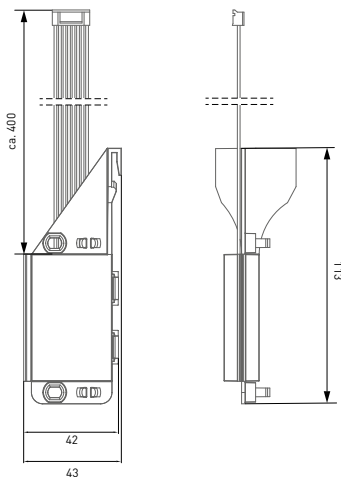

For DucoBox Reno

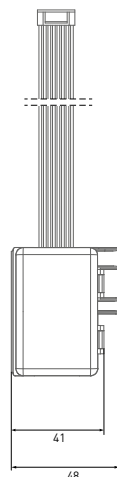

For DucoBox Energy Premium

